

Generator set data sheet



Model: C3000 D5
Frequency: 50 Hz
Fuel type: Diesel

Spec sheet:	SS18-CPGK
-------------	-----------

Fuel consumption	Standby				Prime			
	kVA (kW)				kVA (kW)			
Ratings	3000 (2400)				2750 (2200)			
Load	1/4	1/2	3/4	Full	1/4	1/2	3/4	Full
US gph	46.0	80.5	115.0	150.3	43.0	74.6	106.2	137.8
L/hr	174	305	436	569	163	283	402	522

Engine	Standby rating	Prime rating
Engine manufacturer	Cummins	
Engine model	QSK78-G9	
Configuration	Cast iron, 60° V18 cylinder	
Aspiration	Turbocharged and low temperature after-cooled	
Gross engine power output, kWm	2539	2304
BMEP at set rated load, kPa	2617	2375
Bore, mm	170	
Stroke, mm	190	
Rated speed, rpm	1500	
Piston speed, m/s	9.5	
Compression ratio	15.5:1	
Lube oil capacity, L	413	
Overspeed limit, rpm	1725 ±50	
Regenerative power, kW	189	
Governor type	Electronic	
Starting voltage	24V Volts DC	

Fuel flow	
Maximum fuel flow, L/hr	2225
Maximum fuel inlet restriction, mm Hg (clean filter)	127
Maximum fuel inlet temperature, °C	70

Air	Standby rating	Prime rating
Combustion air, m ³ /min	193	186
Maximum air cleaner restriction, kPa	6.2	

Exhaust		
Exhaust gas flow at set rated load, m ³ /min	432	415
Exhaust gas temperature, °C	427	422
Maximum back pressure, kPa	6.7	

Standard set-mounted radiator cooling		
Ambient design, °C	RTF	
Fan load, kW _m	RTF	
Coolant capacity (with radiator), L	RTF	
Cooling system air flow, m ³ /sec @ 12.7 mmH ₂ O	RTF	
Total heat rejection, Btu/min	RTF	RTF
Maximum cooling air flow static restriction mm H ₂ O	RTF	

Weights*	Open
Unit dry weight kgs	18964
Unit wet weight kgs	19560

* Weights represent a set with standard features. See outline drawing for weights of other configurations.

Dimensions	Length	Width	Height
Standard open set dimensions	5670	2305	2708

Genset outline

Open set

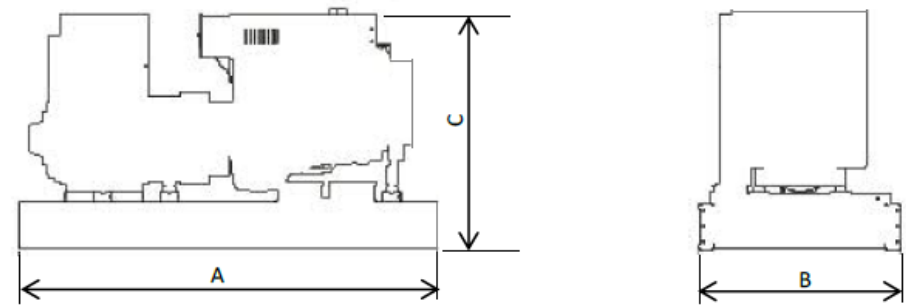

Outlines are for illustrative purposes only. Please refer to the genset outline drawing for an exact representation of this model.

Alternator data

Connection	Temp rise °C	Duty	Alternator	Voltage
Wye, 3-phase	150/125/105	S/P/C	LVSI804T	380-440
Wye, 3-phase	80-150	S/P/C	MVSI804R,S,T,W	3300
Wye, 3-phase	80-125	S/P/C	HVSI804S,T,W,X	6600/11000

Ratings definitions

Emergency standby power (ESP):	Limited-time running power (LTP):	Prime power (PRP):	Base load (Continuous) Power (COP):
Applicable for supplying power to varying electrical load for the duration of power interruption of a reliable utility source. Emergency standby power (ESP) is in accordance with ISO 8528. Fuel stop power in accordance with ISO 3046, AS 2789, DIN 6271 and BS 5514.	Applicable for supplying power to a constant electrical load for limited hours. Limited-time running power (LTP) is in accordance with ISO 8528.	Applicable for supplying power to varying electrical load for unlimited hours. Prime power (PRP) is in accordance with ISO 8528. Ten percent overload capability is available in accordance with ISO 3046, AS 2789, DIN 6271 and BS 5514.	Applicable for supplying power continuously to a constant electrical load for unlimited hours. Continuous power (COP) is in accordance with ISO 8528, ISO 3046, AS 2789, DIN 6271 and BS 5514.

Formulas for calculating full load currents:

Three phase output	Single phase output
$\frac{\text{kW} \times 1000}{\text{Voltage} \times 1.73 \times 0.8}$	$\frac{\text{kW} \times \text{SinglePhaseFactor} \times 1000}{\text{Voltage}}$

For more information contact your local Cummins distributor or visit power.cummins.com

Our energy working for you.™



PowerCommand® 3.3 control system



> Specification sheet

Our energy working for you.™



Power Generation

Control system description

The PowerCommand® control system is a microprocessor-based genset monitoring, metering and control system designed to meet the demands of today's engine driven gensets. The integration of all control functions into a single control system provides enhanced reliability and performance, compared to conventional genset control systems. These control systems have been designed and tested to meet the harsh environment in which gensets are typically applied.

Features

- 320 x 240 pixels graphic LED backlight LCD.
- Multiple language support.
- AmpSentry™ protection - for true alternator overcurrent protection.
- Digital Power Transfer Control (AMF) provides load transfer operation in open transition, closed transition, or soft (ramping) transfer modes.
- Extended Paralleling (Peak Shave/Base Load) regulates the genset real and reactive power output while paralleled to the utility. Power can be regulated at either the genset or utility bus monitoring point.
- Digital frequency synchronization and voltage matching.
- Isochronous Load Share
- Droop KW and KVAR Control
- Real time clock for fault and event time stamping.
- Exerciser clock and time of day start/stop initiate a test with or without load, or a Base Load or Peak Shave session.
- Digital voltage regulation. Three phase full wave FET type regulator compatible with either shunt or PMG systems.
- Digital engine speed governing (where applicable)
- Generator set monitoring and protection.
- Utility/AC Bus metering and protection
- 12 and 24 V DC battery operation.
- Modbus® interface for interconnecting to customer equipment.
- Warranty and service. Backed by a comprehensive warranty and worldwide distributor service network.
- Certifications - Suitable for use on gensets that are designed, manufactured, tested and certified to relevant UL, NFPA, ISO, IEC, Mil Std. and CE standards.

PowerCommand digital genset control

PCC 3300



Description

The PowerCommand genset control is suitable for use on a wide range of diesel and lean burn natural gas gensets in paralleling applications. The PowerCommand control is compatible with shunt or PMG excitation style. It is suitable for use with reconnectable or non-reconnectable generators, and it can be configured for any frequency, voltage and power connection from 120-600 VAC line-to-line, 601-45,000 VAC with external PT.

Power for this control system is derived from the genset starting batteries. The control functions over a voltage range from 8 VDC to 30 VDC.

Features

- 12 and 24 VDC battery operation.
- Digital voltage regulation - Three phase full wave FET type regulator compatible with either shunt or PMG systems. Sensing is three phase.
- Digital engine speed governing (where applicable) – Provides isochronous frequency regulation.
- Full authority engine communications (where applicable) - Provides communication and control with the Engine Control Module (ECM).
- AmpSentry™ protection - for true alternator overcurrent protection.
- Genset monitoring - Monitors status of all critical engine and alternator functions.
- Digital genset metering (AC and DC).
- Genset battery monitoring system to sense and warn against a weak battery condition.
- Configurable for single or three phase AC metering.
- Engine starting - Includes relay drivers for starter, fuel shut off (FSO), glow plug/spark ignition power and switch B+ applications.
- Genset protection – Protects engine and alternator.
- Real time clock for fault and event time stamping.

- Exerciser clock and time of day start/stop initiate a test with or without load, or a Base Load or Peak Shave session.
- Digital Power Transfer Control (AMF) provides load transfer operation in open transition, closed transition, or soft (ramping) transfer modes.
- Extended Paralleling (Peak Shave/Base Load) regulates the genset real and reactive power output while paralleled to the utility. Power can be regulated at either the genset or utility bus monitoring point.
- Digital frequency synchronization and voltage matching.
- Isochronous Load Share
- Droop KW and KVAR Control
- Sync Check – The sync check function has adjustments for phase angle window, voltage window, frequency window and time delay.
- Utility/AC Bus metering and protection
- Advanced serviceability – using InPower™, a PC-based software service tool.
- Environmental protection – The control system is designed for reliable operation in harsh environments. The main control board is a fully encapsulated module that is protected from the elements.
- ModBus interface for interconnecting to customer equipment.
- Configurable inputs and outputs – Four discrete inputs and four dry contact relay outputs.
- Warranty and service – Backed by a comprehensive warranty and worldwide distributor service network.
- Certifications – Suitable for use on gensets that are designed, manufactured, tested and certified to relevant UL, NFPA, ISO, IEC, Mil Std. and CE standards.

Base control functions

HMI capability

Options – Local and remote HMI options

Operator adjustments – The HMI includes provisions for many set up and adjustment functions.

Genset hardware data – Access to the control and software part number, genset rating in KVA and genset model number is provided from the HMI or InPower.

Data logs – Includes engine run time, controller on time, number of start attempts, total kilowatt hours, and load profile. (Control logs data indicating the operating hours at percent of rated kW load, in 5% increments. The data is presented on the operation panel based on total operating hours on the generator.)

Fault history – Provides a record of the most recent fault conditions with control date and time stamp. Up to 32 events are stored in the control non-volatile memory.

Alternator data

Our energy working for you.™

www.cumminspower.com

©2010 Cummins Power Generation Inc. All rights reserved. Cummins Power Generation and Cummins are registered trademarks of Cummins Inc. PowerCommand, AmpSentry, InPower and "Our energy working for you." are trademarks of Cummins Power Generation. Other company, product, or service names may be trademarks or service marks of others. Specifications are subject to change without notice. S-1570b (5/10) Page 2 of 12



- Voltage (single or three phase line-to-line and line-to-neutral)
- Current (single or three phase)
- kW, KVAR, power factor, KVA (three phase and total)
- Frequency

For Lean Burn Natural Gas Engine applications:

- Alternator heater status
- Alternator winding temperature (per phase)
- Alternator drive end bearing temperature
- Alternator non-drive end bearing temperature

Utility/AC bus data

- Voltage (three phase line-to-line and line-to-neutral)
- Current (three phase and total)
- kW, KVAR, power factor, KVA (three phase and total)
- Frequency

Engine data

- Starting battery voltage
- Engine speed
- Engine temperature
- Engine oil pressure
- Engine oil temperature
- Intake manifold temperature
- Coolant temperature
- Comprehensive Full Authority Engine (FAE) data (where applicable)

For Lean Burn Natural Gas Engine applications:

- Safety shutoff valve status
- Valve proving status
- Downstream gas pressure
- Gas inlet pressure
- Gas mass flow rate
- Control valve position
- Gas outlet pressure
- Manifold pressure
- Manifold temperature
- Throttle position
- Compressor outlet pressure
- Turbo speed
- Compressor bypass position
- Cylinder configuration (e.g., drive end and non-drive end configurations)
- Coolant pressure 1 and 2 (e.g., HT and LT)
- Coolant temperature 1 and 2 (e.g., HT and LT)
- Exhaust port temperature (up to 18 cylinders)
- Pre-filter oil pressure
- Exhaust back pressure
- CM700 internal temperature
- CM700 isolated battery voltage
- Speed bias
- CM558 internal temperature
- CM558 isolated battery voltage
- Knock level (up to 18 cylinders)
- Spark advance (up to 18 cylinders)
- Knock count (up to 18 cylinders)
- Auxiliary supply disconnect status

- Engine heater status
- Coolant circulating pump status
- Lube oil priming pump status
- Lube oil status
- Oil heater status
- Derate authorization status
- Start system status
- Ventilator fan status
- Ventilation louvre status
- Radiator fan status
- DC PSU status
- Start inhibit/enable status and setup

Service adjustments – The HMI includes provisions for adjustment and calibration of genset control functions. Adjustments are protected by a password. Functions include:

- Engine speed governor adjustments
- Voltage regulation adjustments
- Cycle cranking
- Configurable fault set up
- Configurable input and output set up
- Meter calibration
- Paralleling setup
- Display language and units of measurement

Engine control

SAE-J1939 CAN interface to full authority ECMs (where applicable). Provides data transfer between genset and engine controller for control, metering and diagnostics.

12 VDC/24 VDC battery operations - PowerCommand will operate either on 12 VDC or 24 VDC batteries.

Temperature dependent governing dynamics (with electronic governing) - modifies the engine governing control parameters as a function of engine temperature. This allows the engine to be more responsive when warm and more stable when operating at lower temperature levels.

Isochronous governing - (where applicable) Capable of controlling engine speed within +/-0.25% for any steady state load from no load to full load. Frequency drift will not exceed +/-0.5% for a 33 °C (60 °F) change in ambient temperature over an 8 hour period.

Droop electronic speed governing - Control can be adjusted to droop from 0 to 10% from no load to full load.

Remote start mode - It accepts a ground signal from remote devices to automatically start the genset and immediately accelerates to rated speed and voltage or run at idle until engine temperature is adequate. The remote start signal will also wake up the control from sleep mode. The control can incorporate a time delay start and stop.

Our energy working for you.™

www.cumminspower.com

©2010 Cummins Power Generation Inc. All rights reserved. Cummins Power Generation and Cummins are registered trademarks of Cummins Inc. PowerCommand, AmpSentry, InPower and "Our energy working for you." are trademarks of Cummins Power Generation. Other company, product, or service names may be trademarks or service marks of others. Specifications are subject to change without notice. S-1570b (5/10) Page 3 of 12



Remote and local emergency stop - The control accepts a ground signal from a local (genset mounted) or remote (facility mounted) emergency stop switch to cause the genset to immediately shut down. The genset is prevented from running or cranking with the switch engaged. In sleep mode, activation of either emergency stop switch will wake up the control.

Sleep mode - The control includes a configurable low current draw state to minimize starting battery current draw when the genset is not operating. The control can also be configured to go into a low current state while in auto for prime applications or applications without a battery charger.

Engine starting - The control system supports automatic engine starting. Primary and backup start disconnects are achieved by one of two methods: magnetic pickup or main alternator output frequency. The control also supports configurable glow plug control when applicable.

Cycle cranking - Is configurable for the number of starting cycles (1 to 7) and duration of crank and rest periods. Control includes starter protection algorithms to prevent the operator from specifying a starting sequence that might be damaging.

Time delay start and stop (cooldown) - Configurable for time delay of 0-300 seconds prior to starting after receiving a remote start signal and for time delay of 0-600 seconds prior to shut down after signal to stop in normal operation modes. Default for both time delay periods is 0 seconds.

For Lean Burn Natural Gas Engine applications:

Engine start inhibit/enable - The function will allow application-specific processes to be started prior to the genset/engine start (e.g., pumps, boosters, etc.).

Alternator control

The control includes an integrated three phase line-to-line sensing voltage regulation system that is compatible with shunt or PMG excitation systems. The voltage regulation system is a three phase full wave rectified and has an FET output for good motor starting capability. Major system features include:

Digital output voltage regulation - Capable of regulating output voltage to within +/-1.0% for any loads between no load and full load. Voltage drift will not exceed +/-1.5% for a 40 °C (104 °F) change in temperature in an eight hour period. On engine starting or sudden load acceptance, voltage is controlled to a maximum of 5% overshoot over nominal level.

The automatic voltage regulator feature can be disabled to allow the use of an external voltage regulator.

Droop voltage regulation - Control can be adjusted to droop from 0-10% from no load to full load.

Torque-matched V/Hz overload control - The voltage roll-off set point and rate of decay (i.e. the slope of the V/Hz curve) is adjustable in the control.

Fault current regulation - PowerCommand will regulate the output current on any phase to a maximum of three times rated current under fault conditions for both single phase and three phase faults. In conjunction with a permanent magnet generator, it will provide three times rated current on all phases for motor starting and short circuit coordination purpose.

Paralleling functions

First Start Sensor™ system - PowerCommand provides a unique control function that positively prevents multiple gensets from simultaneously closing to an isolated bus under black start conditions. The First Start Sensor system is a communication system between the gensets that allows the gensets to work together to determine which genset in a system should be the first to close to the bus. The system includes an independent backup function, so that if the primary system is disabled the required functions are still performed.

Synchronizing - Control incorporates a digital synchronizing function to force the genset to match the frequency, phase and voltage of another source such as a utility grid. The synchronizer includes provisions to provide proper operation even with highly distorted bus voltage waveforms. The synchronizer can match other sources over a range of 60-110% of nominal voltage and -24 to +6 hertz. The synchronizer function is configurable for slip frequency synchronizing for applications requiring a known direction of power flow at instant of breaker closure or for applications where phase synchronization performance is otherwise inadequate.

Load sharing control - The genset control includes an integrated load sharing control system for both real (kW) and reactive (kVar) loads when the genset(s) are operating on an isolated bus. The control system determines kW load on the engine and kVar load on the alternator as a percent of genset capacity, and then regulates fuel and excitation systems to maintain system and genset at the same percent of load without impacting voltage or frequency regulation. The control can also be configured for operation in droop mode for kW or Kvar load sharing.

Our energy working for you.™

www.cumminspower.com

©2010 Cummins Power Generation Inc. All rights reserved. Cummins Power Generation and Cummins are registered trademarks of Cummins Inc. PowerCommand, AmpSentry, InPower and "Our energy working for you." are trademarks of Cummins Power Generation. Other company, product, or service names may be trademarks or service marks of others. Specifications are subject to change without notice. S-1570b (5/10) Page 4 of 12



Load govern control – When PowerCommand receives a signal indicating that the genset is paralleled with an infinite source such as a utility (mains) service, the genset will operate in load govern mode. In this mode the genset will synchronize and close to the bus, ramp to a pre-programmed kW and kVar load level, and then operate at that point. Control is adjustable for kW values from 0-100% of standby rating, and 0.7-1.0 power factor (lagging). Default setting is 80% of standby and 1.0 power factor. The control includes inputs to allow independent control of kW and kVar load level by a remote device while in the load govern mode. The rate of load increase and decrease is also adjustable in the control. In addition, the control can be configured for operation in kW or kVAR load govern droop.

Load demand control – The control system includes the ability to respond to an external signal to initiate load demand operation. On command, the genset will ramp to no load, open its paralleling breaker, cool down, and shut down. On removal of the command, the genset will immediately start, synchronize, connect, and ramp to its share of the total load on the system.

Sync check – The sync check function decides when permissive conditions have been met to allow breaker closure. Adjustable criteria are: phase difference from 0.1-20 deg, frequency difference from 0.001-1.0 Hz, voltage difference from 0.5-10%, and a dwell time from 0.5-5.0 sec. Internally the sync check is used to perform closed transition operations. An external sync check output is also available.

Genset and utility/AC bus source AC metering – The control provides comprehensive three phase AC metering functions for both monitored sources, including: 3-phase voltage (L-L and L-N) and current, frequency, phase rotation, individual phase and totalized values of kW, kVAR, kVA and Power Factor; totalized positive and negative kW-hours, kVAR-hours, and kVA-hours. Three wire or four wire voltage connection with direct sensing of voltages to 600V, and up to 45kV with external transformers. Current sensing is accomplished with either 5 amp or 1 CT secondaries and with up to 10,000 amp primary. Maximum power readings are 32,000kW/kVAR/kVA.

Power transfer control – provides integrated automatic power transfer functions including source availability sensing, genset start/stop and transfer pair monitoring and control. The transfer/retransfer is configurable for open transition, fast closed transition (less than 100msec interconnect time), or soft closed transition (load ramping) sequences of operation. Utility source failure will automatically start genset and transfer load, retransferring when utility source returns. Test will start gensets and transfer load if test with load is enabled. Sensors and timers include:

Under voltage sensor: 3-phase L-N or L-L under voltage sensing adjustable for pickup from 85-100% of nominal. Dropout adjustable from 75-98% of pickup. Dropout delay adjustable from 0.1-30 sec.

Over voltage sensor: 3-phase L-N or L-L over voltage sensing adjustable for pickup from 95-99% of dropout. Dropout adjustable from 105-135% of nominal. Dropout delay adjustable from 0.5-120 sec. Standard configuration is disabled, and is configurable to enabled in the field using the HMI or InPower service tools.

Over/Under frequency sensor: Center frequency adjustable from 45-65 Hz. Dropout bandwidth adjustable from 0.3-5% of center frequency beyond pickup bandwidth. Pickup bandwidth adjustable from 0.3-20% of center frequency. Field configurable to enable.

Loss of phase sensor: Detects out of range voltage phase angle relationship. Field configurable to enable.

Phase rotation sensor: Checks for valid phase rotation of source. Field configurable to enable.

Breaker tripped: If the breaker tripped input is active, the associated source will be considered as unavailable.

Timers: Control provides adjustable start delay from 0-300sec, stop delay from 0-800sec, transfer delay from 0-120sec, retransfer delay from 0-1800sec, programmed transition delay from 0-60sec, and maximum parallel time from 0-1800sec.

Breaker control – Utility and Genset breaker interfaces include separate relays for opening and closing breaker, as well as inputs for both 'a' and 'b' breaker position contacts and tripped status. Breaker diagnostics include Contact Failure, Fail to Close, Fail to Open, Fail to Disconnect, and Tripped. Upon breaker failure, appropriate control action is taken to maintain system integrity.

Extended paralleling – In extended paralleling mode (when enabled) the controller will start the genset and parallel to a utility source and then govern the real and reactive power output of the genset based on the desired control point. The control point for the real power (kW) can be configured for either the genset metering point ("Base Load") or the utility metering point ("Peak Shave"). The control point for the reactive power (kVAR or Power Factor) can also be independently configured for either the genset metering point or the utility metering point. This flexibility would allow base kW load from the genset while maintaining the utility power factor at a reasonable value to avoid penalties due to low power factor. The System always operates within genset ratings. The control point can be changed while the system is in operation. Set points can be adjusted via hardwired analog input or adjusted through an operator panel display or service tool.

Our energy working for you.™

www.cumminspower.com

©2010 Cummins Power Generation Inc. All rights reserved. Cummins Power Generation and Cummins are registered trademarks of Cummins Inc. PowerCommand, AmpSentry, InPower and "Our energy working for you." are trademarks of Cummins Power Generation. Other company, product, or service names may be trademarks or service marks of others. Specifications are subject to change without notice. S-1570b (5/10) Page 5 of 12



Exerciser clock –The exerciser clock (when enabled) allows the system to be operated at preset times in either test without load, test with load, or extended parallel mode. A Real Time Clock is built in. Up to 12 different programs can be set for day of week, time of day, duration, repeat interval, and mode. For example, a test with load for 1 hour every Tuesday at 2AM can be programmed. Up to 6 different exceptions can also be set up to block a program from running during a specific date and time period.

Application types – Controller is configured to operating in one of six possible application types. These topologies are often used in combinations in larger systems, with coordination of the controllers in the system either by external device or by interlocks provided in the control. Topologies that may be selected in the control include:

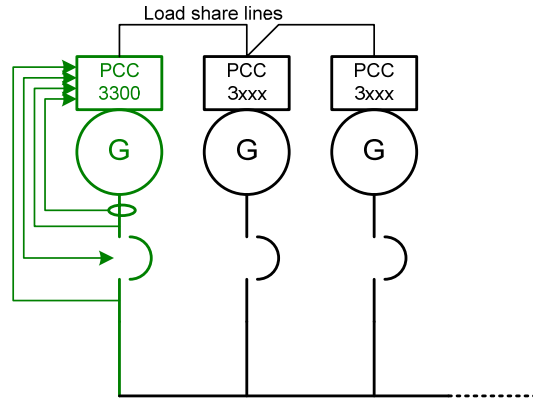

Standalone: Control provides monitoring, protection and control in a non-paralleling application.

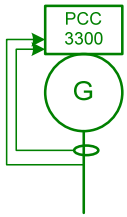

Synchronizer only: control will synchronize the genset to other source when commanded to either via a hardwired or Modbus driven input.

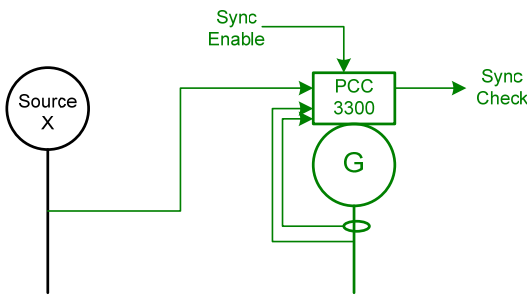

Utility Single: Control monitors one genset and utility. The control will automatically start and provide power to a load if the utility fails. The control will also resynchronize the genset back to the utility and provides extended paralleling capabilities.

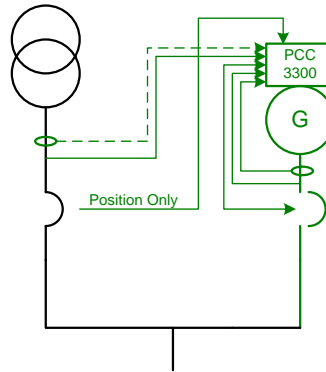

Utility Multiple: Supports all functionality of Isolated Bus and provides extended paralleling to the utility. Extended paralleling load set points follow a constant setting; dynamically follow an analog input, Modbus register or HMI.

Isolated Bus: allows the genset to perform a dead bus closure or synchronize to the bus and isochronously share kW and kVAR loads with other gensets.

Our energy working for you.™

www.cumminspower.com

©2010 Cummins Power Generation Inc. All rights reserved. Cummins Power Generation and Cummins are registered trademarks of Cummins Inc. PowerCommand, AmpSentry, InPower and "Our energy working for you." are trademarks of Cummins Power Generation. Other company, product, or service names may be trademarks or service marks of others. Specifications are subject to change without notice. S-1570b (5/10) Page 6 of 12



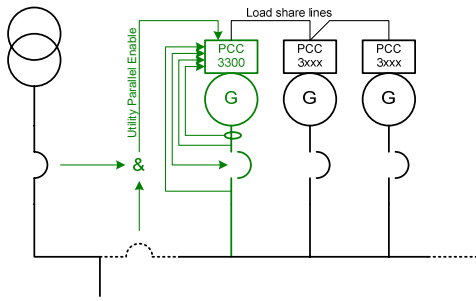

Power Transfer Control: control operates a single genset/single utility transfer pair in open transition, fast closed transition, or soft closed transition. Extended paralleling functionality also provides base load and peak shave options.

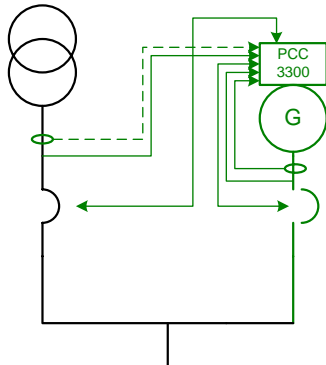

Protective functions

On operation of a protective function the control will indicate a fault by illuminating the appropriate status LED on the HMI, as well as display the fault code and fault description on the LCD. The nature of the fault and time of occurrence are logged in the control. The service manual and InPower service tool provide service keys and procedures based on the service codes provided. Protective functions include:

Battle short mode

When enabled and the *battle short* switch is active, the control will allow some shutdown faults to be bypassed. If a bypassed shutdown fault occurs, the fault code and description will still be annunciated, but the genset will not shutdown. This will be followed by a *fail to shutdown* fault. Emergency stop shutdowns and others that are critical for proper operation (or are handled by the engine ECM) are not bypassed. Please refer to the Control Application Guide or Manual for list of these faults.

Derate

The Derate function reduces output power of the genset in response to a fault condition. If a Derate command occurs while operating on an isolated bus, the control will issue commands to reduce the load on the genset via contact closures or Modbus. If a Derate command occurs while in utility parallel mode, the control will actively reduce power by lowering the base load kW to the derated target kW.

Our energy working for you.™

www.cumminspower.com

©2010 Cummins Power Generation Inc. All rights reserved. Cummins Power Generation and Cummins are registered trademarks of Cummins Inc. PowerCommand, AmpSentry, InPower and "Our energy working for you." are trademarks of Cummins Power Generation. Other company, product, or service names may be trademarks or service marks of others. Specifications are subject to change without notice. S-1570b (5/10) Page 7 of 12

Configurable alarm and status inputs

The control accepts up to four alarm or status inputs (configurable contact closed to ground or open) to indicate a configurable (customer-specified) condition.

The control is programmable for warning, derate, shutdown, shutdown with cooldown or status indication and for labeling the input.

Emergency stop

Annunciated whenever either emergency stop signal is received from external switch.

General engine protection

Low and high battery voltage warning - Indicates status of battery charging system (failure) by continuously monitoring battery voltage.

Weak battery warning - The control system will test the battery each time the genset is signaled to start and indicate a warning if the battery indicates impending failure.

Fail to start (overcrank) shutdown - The control system will indicate a fault if the genset fails to start by the completion of the engine crank sequence.

Fail to crank shutdown - Control has signaled starter to crank engine but engine does not rotate.

Cranking lockout - The control will not allow the starter to attempt to engage or to crank the engine when the engine is rotating.

Fault simulation - The control in conjunction with InPower software, will accept commands to allow a technician to verify the proper operation of the control and its interface by simulating failure modes or by forcing the control to operate outside of its normal operating ranges. InPower also provides a complete list of faults and settings for the protective functions provided by the controller.

For Lean Burn Natural Gas Engine applications:

Off load running (protection) - This feature protects the engine in the event the genset is being called to go off load for too long.

Hydro mechanical fuel system engine protection

Overspeed shutdown - Default setting is 115% of nominal

Low lube oil pressure warning/shutdown - Level is preset (configurable with InPower or HMI) to match the capabilities of the engine used. Control includes time delays to prevent nuisance alarms.

High lube oil temperature warning/shutdown - Level is preset (configurable with InPower or HMI) to match the capabilities of the engine used. Control includes time delays to prevent nuisance alarms.



High engine temperature warning/shutdown – Level is preset (configurable with InPower or HMI) to match the capabilities of the engine used. Control includes time delays to prevent nuisance alarms.

Low coolant temperature warning – Indicates that engine temperature may not be high enough for a 10 second start or proper load acceptance.

Low coolant temperature warning – Can be set up to be a warning or shutdown.

High intake manifold temperature shutdown – Level is preset (configurable with InPower or HMI) to match the capabilities of the engine used. Control includes time delays to prevent nuisance alarms.

Full authority electronic engine protection

Engine fault detection is handled inside the engine ECM. Fault information is communicated via the SAE-J1939 data link for annunciation in the HMI.

Alternator protection

AmpSentry protective relay - A comprehensive monitoring and control system integral to the PowerCommand Control System that guards the electrical integrity of the alternator and power system by providing protection against a wide array of fault conditions in the genset or in the load. It also provides single and three phase fault current regulation so that downstream protective devices have the maximum current available to quickly clear fault conditions without subjecting the alternator to potentially catastrophic failure conditions. See document R1053 for a full size time over current curve. The control does not include protection required for interconnection to a utility (mains) service.

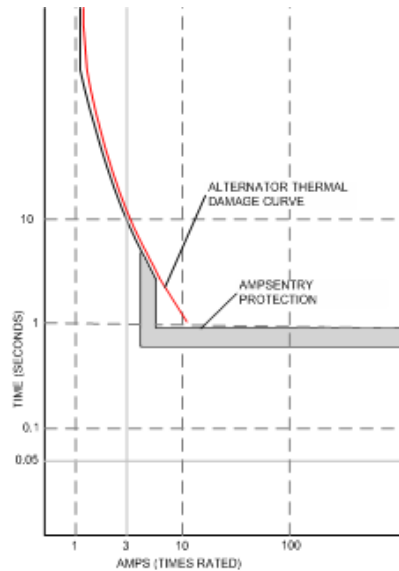

High AC voltage shutdown (59) - Output voltage on any phase exceeds preset values. Time to trip is inversely proportional to amount above threshold. Values adjustable from 105-125% of nominal voltage, with time delay adjustable from 0.1-10 seconds. Default value is 110% for 10 seconds.

Low AC voltage shutdown (27) - Voltage on any phase has dropped below a preset value. Adjustable over a range of 50-95% of reference voltage, time delay 2-20 seconds. Default value is 85% for 10 seconds. Function tracks reference voltage. Control does not nuisance trip when voltage varies due to the control directing voltage to drop, such as during a V/Hz roll-off or synchronizing.

Under frequency shutdown (81 u) - Genset output frequency cannot be maintained. Settings are adjustable from 2-10 Hz below reference governor set point, for a 5-20 second time delay. Default: 6 Hz, 10 seconds. Under frequency protection is disabled when excitation is switched off, such as when engine is operating in idle speed mode.

Over frequency shutdown/warning (81o) - Genset is operating at a potentially damaging frequency level. Settings are adjustable from 2-10 Hz above nominal governor set point for a 1-20 second time delay. Default: 6 Hz, 20 seconds, disabled.

Overcurrent warning/shutdown (51) - Implementation of the thermal damage curve with instantaneous trip level calculated based on current transformer ratio and application power rating.

Loss of sensing voltage shutdown - Shutdown of genset will occur on loss of voltage sensing inputs to the control.

Field overload shutdown - Monitors field voltage to shutdown genset when a field overload condition occurs.

Over load (kW) warning - Provides a warning indication when engine is operating at a load level over a set point. Adjustment range: 80-140% of application rated kW, 0-120 second delay. Defaults: 105%, 60 seconds.

Reverse power shutdown (32) - Adjustment range: 5-20% of standby kW rating, delay 1-15 seconds. Default: 10%, 3 seconds.

Reverse Var shutdown - Shutdown level is adjustable: 15-50% of rated Var output, delay 10-60 seconds. Default: 20%, 10 seconds.

Short circuit protection - Output current on any phase is more than 175% of rating and approaching the thermal damage point of the alternator. Control includes algorithms to protect alternator from repeated over current conditions over a short period of time.

Negative sequence overcurrent warning (46) – Control protects the generator from damage due to excessive imbalances in the three phase load currents and/or power factors.

Our energy working for you.™

www.cumminspower.com

Custom overcurrent warning/shutdown (51) – Control provides the ability to have a custom time overcurrent protection curve in addition to the AmpSentry protective relay function.

Ground fault overcurrent (51G) – Control detects a ground fault either by an external ground fault relay via a contact input or the control can measure the ground current from an external current transformer. Associated time delays and thresholds are adjustable via InPower or HMI.

Paralleling protection

Breaker fail to close Warning: When the control signals a circuit breaker to close, it will monitor the breaker auxiliary contacts and verify that the breaker has closed. If the control does not sense a breaker closure within an adjustable time period after the close signal, the fail to close warning will be initiated.

Breaker fail to open warning: The control system monitors the operation of breakers that have been signaled to open. If the breaker does not open within an adjustable time delay, a Breaker Fail to Open warning is initiated.

Breaker position contact warning: The controller will monitor both ‘a’ and ‘b’ position contacts from the breaker. If the contacts disagree as to the breaker position, the breaker position contact warning will be initiated.

Breaker tripped warning: The control accepts inputs to monitor breaker trip / bell alarm contact and will initiate a breaker tripped warning if it should activate.

Fail to disconnect warning: In the controller is unable to open either breaker, a fail to disconnect warning is initiated. Typically this would be mapped to a configurable output, allowing an external device to trip a breaker.

Fail to synchronize warning: Indicates that the genset could not be brought to synchronization with the bus. Configurable for adjustable time delay of 10 -900 seconds, 120 default.

Phase sequence sensing warning: Verifies that the genset phase sequence matches the bus prior to allowing the paralleling breaker to close.

Maximum parallel time warning (power transfer control mode only): During closed transition load transfers, control independently monitors paralleled time. If time is exceeded, warning is initiated and genset is disconnected.

Bus or genset PT input calibration warning: The control system monitors the sensed voltage from the bus and genset output voltage potential transformers. When the paralleling breaker is closed, it will indicate a warning condition if the read values are different.

Field control interface

Input signals to the PowerCommand control include:

- Coolant level (where applicable)
- Fuel level (where applicable)
- Remote emergency stop
- Remote fault reset
- Remote start
- Rupture basin
- Start type signal
- Battle short
- Load demand stop
- Synchronize enable
- Genset circuit breaker inhibit
- Utility circuit breaker inhibit
- Single mode verify
- Transfer inhibit – prevent transfer to utility (in power transfer control mode)
- Retransfer inhibit – prevent retransfer to genset (in power transfer control mode)
- kW and kVAR load setpoints
- Configurable inputs - Control includes (4) input signals from customer discrete devices that are configurable for warning, shutdown or status indication, as well as message displayed

For Lean Burn Natural Gas Engine applications:

- Gearbox oil pressure/temperature protection
- Fire fault
- Earth fault
- Differential fault
- DC power supply fault
- Genset Interface Box (GIB) isolator open fault
- Start inhibit/enable (x3)
- Radiator fan trip
- Ventilator fan trip
- Ventilation louvers closed
- Start system trip
- Alternator heater trip
- Alternator heater status
- Alternator winding temperature (PT100 RTDx3)
- Alternator drive end bearing temperature (PT100 RTD)
- Alternator non-drive end bearing temperature (PT100 RTD)

Output signals from the PowerCommand control include:

- Load dump signal: Operates when the genset is in an overload condition.
- Delayed off signal: Time delay based output which will continue to remain active after the control has removed the run command. Adjustment range: 0 - 120 seconds. Default: 0 seconds.

Our energy working for you.™

www.cumminspower.com

©2010 Cummins Power Generation Inc. All rights reserved. Cummins Power Generation and Cummins are registered trademarks of Cummins Inc. PowerCommand, AmpSentry, InPower and "Our energy working for you." are trademarks of Cummins Power Generation. Other company, product, or service names may be trademarks or service marks of others. Specifications are subject to change without notice. S-1570b (5/10) Page 9 of 12



- Configurable relay outputs: Control includes (4) relay output contacts (3 A, 30VDC). These outputs can be configured to activate on any control warning or shutdown fault as well as ready to load, not in auto, common alarm, common warning and common shutdown.
- Ready to load (genset running) signal: Operates when the genset has reached 90% of rated speed and voltage and latches until genset is switched to off or idle mode.
- Paralleling circuit breaker relays outputs: Control includes (4) relay output contacts (3.5A, 30 VDC) for opening and closing of the genset and utility breakers.

For Lean Burn Natural Gas Engine applications:

- Start inhibit/enable event
- Emergency stop event
- Ventilator fan run control
- Louvre control
- Radiator fan control
- Alternator heater control
- Engine at idle speed event

Communications connections include:

- PC tool interface: This RS-485 communication port allows the control to communicate with a personal computer running InPower software.
- Modbus RS-485 port: Allows the control to communicate with external devices such as PLCs using Modbus protocol.

Note - An RS-232 or USB to RS-485 converter is required for communication between PC and control.

- Networking: This RS-485 communication port allows connection from the control to the other Cummins Power Generation products.

Mechanical drawing

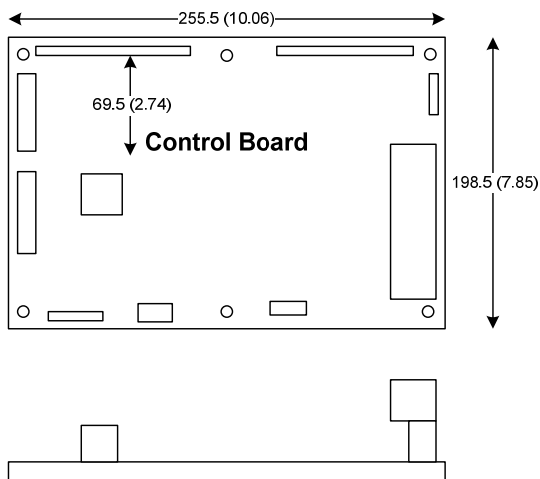

PowerCommand human machine interface HMI320



Description

This control system includes an intuitive operator interface panel that allows for complete genset control as well as system metering, fault annunciation, configuration and diagnostics. The interface includes five genset status LED lamps with both internationally accepted symbols and English text to comply with customers needs. The interface also includes an LED backlit LCD display with tactile feel soft-switches for easy operation and screen navigation. It is configurable for units of measurement and has adjustable screen contrast and brightness.

The *run/off/auto* switch function is integrated into the interface panel.

All data on the control can be viewed by scrolling through screens with the navigation keys. The control displays the current active fault and a time-ordered history of the five previous faults.

Features:

- LED indicating lamps
 - genset running
 - remote start
 - not in auto
 - shutdown
 - warning
 - auto
 - manual and stop
 - Circuit breaker open (if equipped)
 - Circuit breaker closed (if equipped)
- 320 x 240 pixels graphic LED backlight LCD.
- Four tactile feel membrane switches for LCD defined operation. The functions of these switches are defined dynamically on the LCD.
- Seven tactile feel membrane switches dedicated screen navigation buttons for up, down, left, right, ok, home and cancel.

Our energy working for you.™

www.cumminspower.com



- Six tactile feel membrane switches dedicated to control for auto, stop, manual, manual start, fault reset and lamp test/panel lamps.
- Two tactile feel membrane switches dedicated to control of circuit breaker (where applicable).
- Allows for complete genset control setup.
- Certifications: Suitable for use on gensets that are designed, manufactured, tested and certified to relevant UL, NFPA, ISO, IEC, Mil Std. and CE standards.
- LCD languages supported: English, Spanish, French, German, Italian, Greek, Dutch, Portuguese, Finnish, Norwegian, Danish, Russian and Chinese Characters.

Communications connections include:

- PC tool interface - This RS-485 communication port allows the HMI to communicate with a personal computer running InPower.
- This RS-485 communication port allows the HMI to communicate with the main control board.

Mechanical drawing

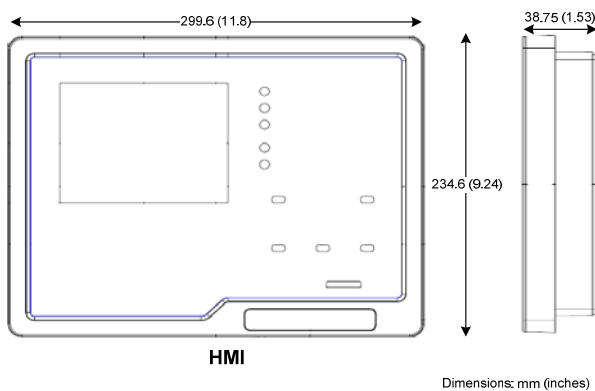

Software

InPower (beyond 6.5 version) is a PC-based software service tool that is designed to directly communicate to PowerCommand gensets and transfer switches, to facilitate service and monitoring of these products.

Environment

The control is designed for proper operation without recalibration in ambient temperatures from -40 °C (-40 °F) to +70° C (158 °F), and for storage from -55 °C (-67 °F) to +80 °C (176 °F). Control will operate with humidity up to 95%, non-condensing.

The HMI is designed for proper operation in ambient temperatures from -20 °C (-4 °F) to +70 °C (158 °F), and for storage from -30 °C (-22 °F) to +80 °C (176 °F).

The control board is fully encapsulated to provide superior resistance to dust and moisture. Display panel has a single membrane surface, which is impervious to effects of dust, moisture, oil and exhaust fumes. This panel uses a sealed membrane to provide long reliable service life in harsh environments.

The control system is specifically designed and tested for resistance to RFI/EMI and to resist effects of vibration to provide a long reliable life when mounted on a genset. The control includes transient voltage surge suppression to provide compliance to referenced standards.

Certifications

PowerCommand meets or exceeds the requirements of the following codes and standards:

- NFPA 110 for level 1 and 2 systems.
- ISO 8528-4: 1993 compliance, controls and switchgear.
- CE marking: The control system is suitable for use on generator sets to be CE-marked.
- EN 50081-1,2 residential/light industrial emissions or industrial emissions.
- EN 50082-1,2 residential/light industrial or industrial susceptibility.
- ISO 7637-2, level 2; DC supply surge voltage test.
- Mil Std 202C, Method 101 and ASTM B117: Salt fog test.
- UL 508 recognized or Listed and suitable for use on UL 2200 Listed generator sets.
- CSA C282-M1999 compliance
- CSA 22.2 No. 14 M91 industrial controls.
- PowerCommand control systems and generator sets are designed and manufactured in ISO 9001 certified facilities.

Warranty

All components and subsystems are covered by an express limited one year warranty. Other optional and extended factory warranties and local distributor maintenance agreements are available.

Our energy working for you.™

www.cumminspower.com

©2010 Cummins Power Generation Inc. All rights reserved. Cummins Power Generation and Cummins are registered trademarks of Cummins Inc. PowerCommand, AmpSentry, InPower and "Our energy working for you." are trademarks of Cummins Power Generation. Other company, product, or service names may be trademarks or service marks of others. Specifications are subject to change without notice. S-1570b (5/10) Page 11 of 12



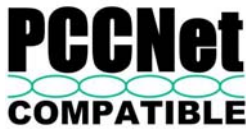

See your distributor for more information

Cummins Power Generation

Americas

1400 73rd Avenue N.E.
Minneapolis, MN 55432 USA
Phone: 763 574 5000
Fax: 763 574 5298

Europe, CIS, Middle East and Africa

Manston Park Columbus Ave.
Manston Ramsgate
Kent CT 12 5BF United Kingdom
Phone 44 1843 255000
Fax 44 1843 255902

Asia Pacific

10 Toh Guan Road #07-01
TT International Tradepark
Singapore 608838
Phone 65 6417 2388
Fax 65 6417 2399

Warning: Back feed to a utility system can cause electrocution and/or property damage. Do not connect to any building's electrical system except through an approved device or after building main switch is open.

Our energy working for you.™

www.cumminspower.com

©2010 Cummins Power Generation Inc. All rights reserved. Cummins Power Generation and Cummins are registered trademarks of Cummins Inc. PowerCommand, AmpSentry, InPower and "Our energy working for you." are trademarks of Cummins Power Generation. Other company, product, or service names may be trademarks or service marks of others. Specifications are subject to change without notice. S-1570b (5/10) Page 12 of 12

