

Generator set data sheet



Model: C150 D5
Frequency: 50 Hz
Fuel type: Diesel

Spec sheet:	SS28-CPGK
Noise data sheet (open/enclosed):	ND50-CS550
Airflow data sheet:	AF50-550
Derate data sheet (open/enclosed):	TBD
Transient data sheet:	TD50-550

Fuel consumption	Standby				Prime			
	kVA (kW)				kVA (kW)			
Ratings	150 (120)				136 (109)			
Load	1/4	1/2	3/4	Full	1/4	1/2	3/4	Full
gph	3.30	4.6	7.7	9.5	3.2	4.2	6.6	8.2
L/hr	12.50	17.50	29.00	36.00	12.00	16.00	25.00	31.20

Engine	Standby rating	Prime rating
Engine manufacturer	TCL	
Engine model	6BTAA5.9-G6	
Configuration	4-cycle, in-line, 6-cylinder	
Aspiration	Turbocharged and charged air-cooled	
Gross engine power output, kWm	145	135
BMEP at set rated load, kPa	2008	1831
Bore, mm	102	
Stroke, mm	120	
Rated speed, rpm	1500	
Piston speed, m/s	6	
Compression ratio	16.5 :1	
Lube oil capacity, L	16.4	
Overspeed limit, rpm	1800	
Regenerative power, kW	NA	
Governor type	Electronic	
Starting voltage	12 V	

Fuel flow	
Maximum fuel flow, L/hr	45
Maximum fuel inlet restriction, mm Hg	101/203 (clean/dirty filter)
Maximum fuel inlet temperature, °C	71

Air	Standby rating	Prime rating
Combustion air, m ³ /min	8.95	8.35
Maximum air cleaner restriction, kPa	3.74	

Exhaust

Exhaust gas flow at set rated load, m ³ /min	31	29
Exhaust gas temperature, °C	520	519
Maximum exhaust back pressure, kPa	10.15	

Standard set-mounted radiator cooling

Ambient design, °C	50	
Fan load, kWm	9.8	
Coolant capacity (with radiator), L	22.1	
Cooling system air flow, m ³ /sec @ 12.7 mm H ₂ O	3.77	
Total heat rejection, Btu/min	4071	3867
Maximum cooling air flow static restriction mm H ₂ O	12.7	

Weights*

	Open	Enclosed
Unit dry weight kgs	1635	2390
Unit wet weight kgs	1650	2400

* Weights represent a set with standard features. See outline drawing for weights of other configurations.

Dimensions

	Length	Width	Height
Standard open set dimensions mm	2537	1090	1846
Enclosed set standard dimensions mm	3460	1090	2387

Genset outline

Open set

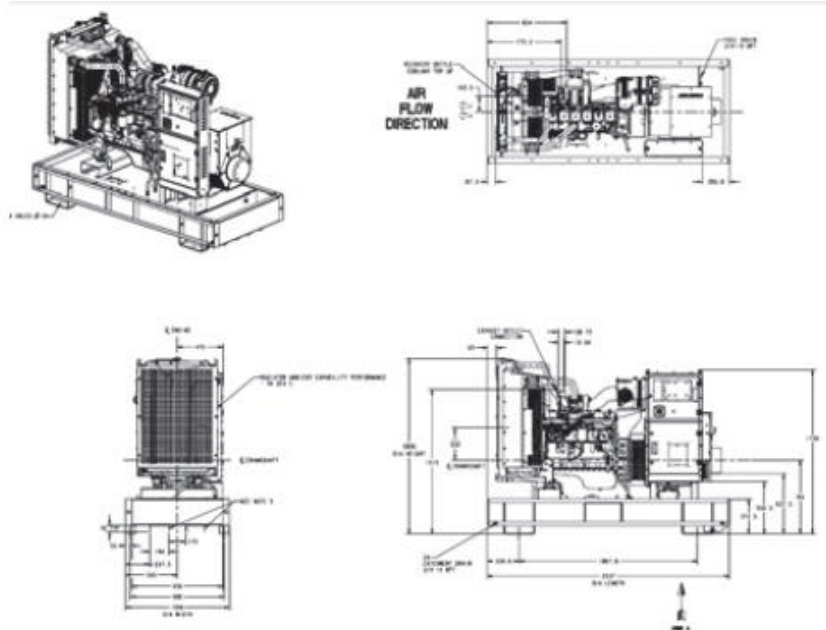

Enclosed set

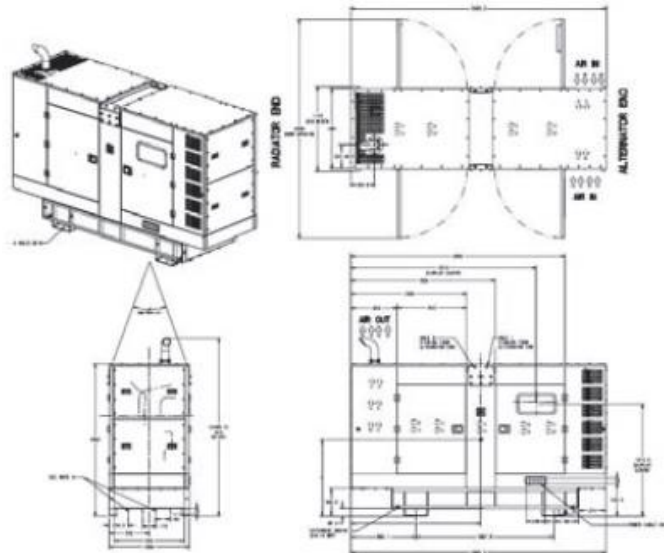

Outlines are for illustrative purposes only. Please refer to the genset outline drawing for an exact representation of this model.

Alternator data

Connection ¹	Temp rise °C	Duty ²	Alternator	Voltage
Wye	163	ESP	UCI274E	190 - 208 & 380 - 416 V
Wye	150	ESP	UCI274F	190 - 208 & 380 - 416 V
Wye	125	PRP	UCI274E	190 - 208 & 380 - 416 V
Wye	105	PRP	UCI274F	190 - 208 & 380 - 416 V

Ratings definitions

Emergency Standby Power (ESP):	Limited-Time Running Power (LTP):	Prime Power (PRP):	Base Load (Continuous) Power (COP):
Applicable for supplying power to varying electrical load for the duration of power interruption of a reliable utility source. Emergency Standby Power (ESP) is in accordance with ISO 8528. Fuel Stop power in accordance with ISO 3046, AS 2789, DIN 6271 and BS 5514.	Applicable for supplying power to a constant electrical load for limited hours. Limited-Time Running Power (LTP) is in accordance with ISO 8528.	Applicable for supplying power to varying electrical load for unlimited hours. Prime Power (PRP) is in accordance with ISO 8528. Ten percent overload capability is available in accordance with ISO 3046, AS 2789, DIN 6271 and BS 5514.	Applicable for supplying power continuously to a constant electrical load for unlimited hours. Continuous Power (COP) is in accordance with ISO 8528, ISO 3046, AS 2789, DIN 6271 and BS 5514.

Formulas for calculating full load currents:

Three phase output	Single phase output
$\frac{\text{kW} \times 1000}{\text{Voltage} \times 1.73 \times 0.8}$	$\frac{\text{kW} \times \text{Single Phase Factor} \times 1000}{\text{Voltage}}$

For more information contact your local Cummins distributor or visit power.cummins.com

Our energy working for you.™



PowerCommand® 1.2 control system



> Specification sheet

Our energy working for you.™



Control system description

The PowerCommand® control system is a microprocessor-based generator set monitoring, metering and control system designed to meet the demands of today's engine driven generator sets. The integration of all control functions into a single control system provides enhanced reliability and performance compared to conventional generator set control systems. These control systems have been designed and tested to meet the harsh environment in which gensets are typically applied.

Features

- 128 x 128 pixels graphic LED backlight LCD.
- Digital voltage regulation. Single phase full wave SCR type regulator compatible with either shunt or PMG systems.
- Digital engine speed governing (where applicable).
- Generator set monitoring and protection.
- Advanced overcurrent protection.
- Modbus® interface for interconnecting to customer equipment.
- 12 and 24 VDC battery operation.
- Warranty and service. Backed by a comprehensive warranty and worldwide distributor service network.
- Certification. Suitable for use on generator sets that are designed, manufactured, tested and certified to relevant UL, NFPA, ISO, IEC Mil Std., CE and CSA standards.

PowerCommand digital generator set control PCC 1302



Description

The PowerCommand generator set control is suitable for use on a wide range of generator sets in non-parallel applications. The PowerCommand control is compatible with shunt or PMG excitation style. It is suitable for use with reconnectable or non-reconnectable generators, and it can be configured for any frequency, voltage and power connection from 120-600 VAC line-to-line.

Power for this control system is derived from the generator set starting batteries. The control functions over a voltage range from 8 VDC to 30 VDC.

Features

- 12 and 24 VDC battery operation.
- Digital voltage regulation - Single phase full wave SCR type regulator compatible with either shunt or PMG systems. Sensing is single phase.
- Digital engine speed governing (where applicable) - Provides isochronous frequency regulation.
- Full authority engine communications (where applicable) - Provides communication and control with the Engine Control Module (ECM).
- Common harnessing - with higher feature Cummins Power Generation controls allows for easy field upgrades.
- Generator set monitoring - Monitors status of all critical engine and alternator functions.
- Digital genset metering (AC and DC).
- Genset battery monitoring system - to sense and warn against a weak battery condition.
- Engine starting - Includes relay drivers for starter, fuel shut off (FSO), glow plug/spark ignition power and switch B+ applications.
- Generator set protection - Protects engine and alternator.
- Advanced serviceability - using InPower™, a PC-based software service tool.
- Environmental protection - The control system is

Our energy working for you.™

www.cumminspower.com

©2007 | Cummins Power Generation Inc. | All rights reserved | Specifications subject to change without notice | Cummins Power Generation and Cummins are registered trademarks of Cummins Inc. PowerCommand, InPower and "Our energy working for you." are trademarks of Cummins Power Generation. Other company, product, or service names may be trademarks or service marks of others. S-1567b (4/08) Page 2 of 6

designed for reliable operation in harsh environments. The main control board is a fully encapsulated module that is protected from the elements.

- Modbus interface - for interconnecting to customer equipment.
- Configurable inputs and outputs - Four discrete inputs and two dry contact relay outputs.
- Warranty and service - Backed by a comprehensive warranty and worldwide distributor service network.
- Certifications - Suitable for use on generator sets that are designed, manufactured, tested and certified to relevant UL, NFPA, ISO, IEC, Mil Std., CE and CSA standards.

Base control functions

HMI capability

Operator adjustments - The HMI includes provisions for many set up and adjustment functions.

Generator set hardware data - Access to the control and software part number, generator set rating in KVA and generator set model number is provided from the HMI or InPower.

Data logs - Includes engine run time, controller on time, number of start attempts.

Fault history - Provides a record of the most recent fault conditions with control hours time stamp. Up to 10 events are stored in the control non-volatile memory.

Alternator data

- Voltage (single or three phase line-to-line and line-to-neutral)
- Current (single or three phase)
- KVA (three phase and total)
- Frequency

Engine data

- Starting battery voltage
- Engine speed
- Engine temperature
- Engine oil pressure
- Partial Full Authority Engine (FAE) data (where applicable)

Service adjustments - The HMI includes provisions for adjustment and calibration of generator set control functions. Adjustments are protected by a password. Functions include:

- Engine speed governor adjustments
- Voltage regulation adjustments
- Cycle cranking
- Configurable fault set up
- Configurable output set up
- Meter calibration
- Units of measurement



Engine control

SAE-J1939 CAN interface to full authority ECMs (where applicable) - Provides data swapping between genset and engine controller for control, metering and diagnostics.

12 VDC/24 VDC battery operations - PowerCommand will operate either on 12 VDC or 24 VDC batteries.

Isochronous governing (where applicable) - Capable of controlling engine speed within +/-0.25% for any steady state load from no load to full load. Frequency drift will not exceed +/-0.5% for a 33 °C (60 °F) change in ambient temperature over an 8 hour period.

Temperature dependent governing dynamics (with electronic governing) - Modifies the engine governing control parameters as a function of engine temperature. This allows the engine to be more responsive when warm and more stable when operating at lower temperature levels.

Remote start mode - Accepts a ground signal from remote devices to automatically start the generator set and immediately accelerate to rated speed and voltage. The remote start signal will also wake up the control from sleep mode. The control can incorporate a time delay start and stop.

Remote and local emergency stop - The control accepts a ground signal from a local (genset mounted) or remote (facility mounted) emergency stop switch to cause the generator set to immediately shut down. The generator set is prevented from running or cranking with the switch engaged. If in sleep mode, activation of either emergency stop switch will wake up the control.

Sleep mode - The control includes a configurable low current draw state to minimize starting battery current draw when the genset is not operating. The control can also be configured to go into a low current state while in auto for prime applications or applications without a battery charger.

Engine starting - The control system supports automatic engine starting. Primary and backup start disconnects are achieved by one of three methods: magnetic pickup, battery charging alternator feedback or main alternator output frequency. The control also supports configurable glow plug control when applicable.

Cycle cranking - Configurable for the number of starting cycles (1 to 7) and duration of crank and rest periods. Control includes starter protection algorithms to prevent the operator from specifying a starting sequence that might be damaging.

Time delay start and stop (cooldown) - Configurable for time delay of 0-300 seconds prior to starting after receiving a remote start signal and for time delay of 0-600 seconds prior to shut down after signal to stop in normal operation modes. Default for both time delay periods is 0 seconds.

Alternator control

The control includes an integrated line-to-line sensing voltage regulation system that is compatible with shunt or PMG excitation systems. The voltage regulation system is full wave rectified and has an SCR output for good motor starting capability. Major system features include:

Digital output voltage regulation - Capable of regulating output voltage to within +/-1.0% for any loads between no load and full load. Voltage drift will not exceed +/-1.5% for a 40 °C (104 °F) change in temperature in an eight hour period. On engine starting or sudden load acceptance, voltage is controlled to a maximum of 5% overshoot over nominal level.

The automatic voltage regulator feature can be disabled to allow the use of an external voltage regulator.

Torque-matched V/Hz overload control - The voltage roll-off set point and rate of decay (i.e. the slope of the V/Hz curve) is adjustable in the control.

Protective functions

On operation of a protective function the control will indicate a fault by illuminating the appropriate status LED on the HMI, as well as display the fault code and fault description on the LCD. The nature of the fault and time of occurrence are logged in the control. The service manual and InPower service tool provide service keys and procedures based on the service codes provided. Protective functions include:

Configurable alarm and status inputs

The control accepts up to four alarm or status inputs (configurable contact closed to ground or open) to indicate a configurable (customer-specified) condition. The control is programmable for warning, shutdown or status indication and for labeling the input.

Emergency stop

Annunciated whenever either emergency stop signal is received from external switch.

Our energy working for you.™

www.cumminspower.com

©2007 | Cummins Power Generation Inc. | All rights reserved | Specifications subject to change without notice | Cummins Power Generation and Cummins are registered trademarks of Cummins Inc. PowerCommand, InPower and "Our energy working for you." are trademarks of Cummins Power Generation. Other company, product, or service names may be trademarks or service marks of others. S-1567b (4/08) Page 3 of 6



Hydro mechanical fuel system engine protection

Overspeed shutdown - Default setting is 115% of nominal.

Low lube oil pressure warning/shutdown - Level is preset (configurable with InPower) to match the capabilities of the engine used. Control includes time delays to prevent nuisance shutdown signals.

High lube oil temperature warning/shutdown - Level is preset (configurable with InPower) to match the capabilities of the engine used. Control includes time delays to prevent nuisance shutdown signals.

High engine temperature warning/shutdown - Level is preset (configurable with InPower) to match the capabilities of the engine used. Control includes time delays to prevent nuisance shutdown signals.

Low coolant temperature warning - Indicates that engine temperature may not be high enough for a 10 second start or proper load acceptance.

Sensor failure indication - Logic is provided on the base control to detect analog sensor or interconnecting wiring failures.

Full authority electronic engine protection

Engine fault detection is handled inside the engine ECM. Fault information is communicated via the SAE-J1939 data link for annunciation in the HMI.

General engine protection

Low and high battery voltage warning - Indicates status of battery charging system (failure) by continuously monitoring battery voltage.

Weak battery warning - The control system will test the battery each time the generator set is signaled to start and indicate a warning if the battery indicates impending failure.

Fail to start (overcrank) shutdown - The control system will indicate a fault if the generator set fails to start by the completion of the engine crank sequence.

Fail to crank shutdown - Control has signaled starter to crank engine but engine does not rotate.

Cranking lockout - The control will not allow the starter to attempt to engage or to crank the engine when the engine is rotating.

Alternator protection

High AC voltage shutdown (59) - Output voltage on any phase exceeds preset values. Time to trip is inversely proportional to amount above threshold. Values adjustable from 105-130% of nominal voltage, with time delay adjustable from 0.1-10 seconds. Default value is 110% for 10 seconds.

Low AC voltage shutdown (27) - Voltage on any phase has dropped below a preset value. Adjustable over a range of 50-95% of reference voltage, time delay 2-20 seconds. Default value is 85% for 10 seconds.

Overcurrent warning/shutdown - Implementation of the thermal damage curve with instantaneous trip level calculated based on current transformer ratio and application power rating.

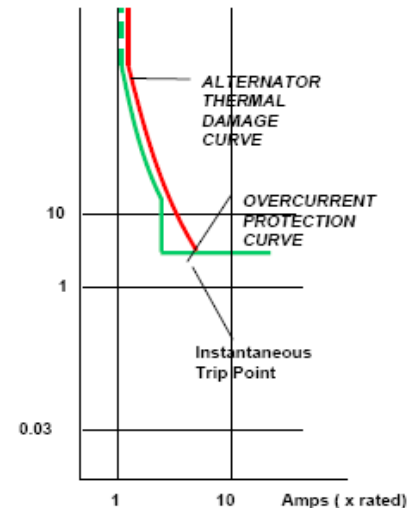

Under frequency shutdown (81 u) - Generator set output frequency cannot be maintained. Settings are adjustable from 2-10 Hz below nominal governor set point, for a 5-20 second time delay. Default: 6 Hz, 10 seconds.

Over frequency shutdown/warning (81o) - Generator set is operating at a potentially damaging frequency level. Settings are adjustable from 2-10 Hz above nominal governor set point for a 1-20 second time delay. Default: 6 Hz, 10 seconds, enabled.

Loss of sensing voltage shutdown - Shutdown of generator set will occur on loss of voltage sensing inputs to the control.

Field overload shutdown - Uses field voltage to shutdown generator set when a field overload condition occurs.

Field control interface

Input signals to the base control include:

- Remote start
- Local and emergency stop
- Configurable inputs: Control includes (4) input signals from customer discrete devices that are configurable for warning, shutdown or status indication, as well as message displayed

Our energy working for you.™

www.cumminspower.com

©2007 | Cummins Power Generation Inc. | All rights reserved | Specifications subject to change without notice | Cummins Power Generation and Cummins are registered trademarks of Cummins Inc. PowerCommand, InPower and "Our energy working for you." are trademarks of Cummins Power Generation. Other company, product, or service names may be trademarks or service marks of others. S-1567b (4/08) Page 4 of 6



Output signals from the PowerCommand control include:

- Configurable relay outputs: Control includes (2) relay output contacts rated at 2 A. These outputs can be configured to activate on any control warning or shutdown fault as well as ready to load, not in auto, common alarm, common warning and common shutdown.
- Ready to load (generator set running) signal: Operates when the generator set has reached 90% of rated speed and voltage and latches until generator set is switched to off or idle mode.

Communications connections include:

- PC tool interface: This RS-485 communication port allows the control to communicate with a personal computer running InPower or PowerCommand for Windows® software.
 - Modbus RS-485 port: Allows the control to communicate with external devices such as PLCs using Modbus protocol.
- Note - An RS-232 or USB to RS-485 converter is required for communication between PC and control.
- Networking: This RS-485 communication port allows connection from the control to the other Cummins Power Generation products.

Mechanical drawings

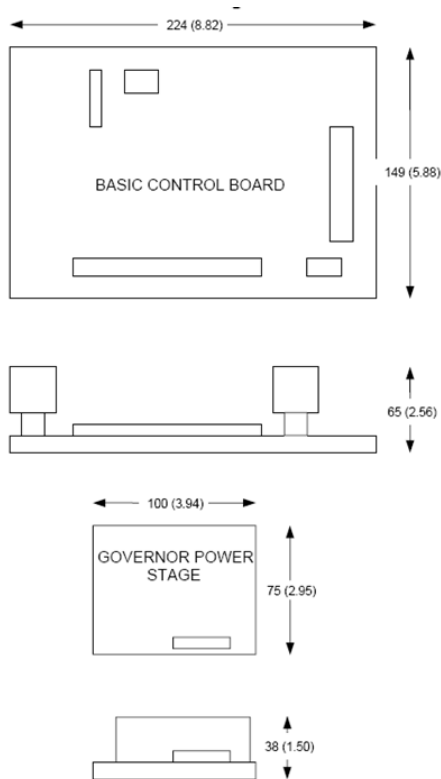

Our energy working for you.™

www.cumminspower.com

©2007 | Cummins Power Generation Inc. | All rights reserved | Specifications subject to change without notice | Cummins Power Generation and Cummins are registered trademarks of Cummins Inc. PowerCommand, InPower and "Our energy working for you." are trademarks of Cummins Power Generation. Other company, product, or service names may be trademarks or service marks of others. S-1567b (4/08) Page 5 of 6

PowerCommand human machine interface HMI220



Description

This control system includes an intuitive operator interface panel that allows for complete genset control as well as system metering, fault annunciation, configuration and diagnostics. The interface includes five generator set status LED lamps with both internationally accepted symbols and English text to comply with customers needs. The interface also includes an LED backlit LCD display with tactile feel soft-switches for easy operation and screen navigation. It is configurable for units of measurement and has adjustable screen contrast and brightness.

The *run/off/auto* switch function is integrated into the interface panel.

All data on the control can be viewed by scrolling through screens with the navigation keys. The control displays the current active fault and a time-ordered history of the five previous faults.

Features:

- LED indicating lamps
 - genset running
 - remote start
 - not in auto
 - shutdown
 - warning
 - auto
 - manual and stop
- 128 x 128 pixels graphic LED backlight LCD.
- Two tactile feel membrane switches for LCD defined operation. The functions of these switches are defined dynamically on the LCD.
- Seven tactile feel membrane switches dedicated screen navigation buttons for up, down, left, right, ok, home and cancel.
- Six tactile feel membrane switches dedicated to control for auto, stop, manual, manual start, fault reset and lamp test/panel lamps.
- Two tactile feel membrane switches dedicated to control of circuit breaker (where applicable).
- Allows for complete genset control setup.



- Certifications: Suitable for use on generator sets that are designed, manufactured, tested and certified to relevant UL, NFPA, ISO, IEC, Mil Std., CE and CSA standards.

LCD languages supported: English, Spanish, French, German, Italian, Greek, Dutch, Portuguese, Finish, Norwegian, Danish, Russian, Czech and Chinese Characters.

Communications connections include:

- PC tool interface - This RS-485 communication port allows the HMI to communicate with a personal computer running InPower.
- This RS-485 communication port allows the HMI to communicate with the main control board.

Mechanical drawing

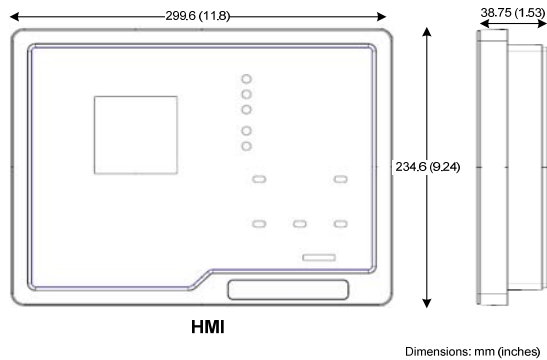

Software

InPower (beyond 6.0 version) is a PC-based software service tool that is designed to directly communicate to PowerCommand generator sets and transfer switches, to facilitate service and monitoring of these products.

Environment

The control is designed for proper operation without recalibration in ambient temperatures from -40 °C (104 °F) to +70° C (158 °F), and for storage from -55 °C (131 °F) to +80 °C (176 °F). Control will operate with humidity up to 95%, non-condensing.



See your distributor for more information

Cummins Power Generation

Americas
 1400 73rd Avenue N.E.
 Minneapolis, MN 55432 USA
 Phone: 763 574 5000
 Fax: 763 574 5298

Europe, CIS, Middle East and Africa
 Manston Park Columbus Ave.
 Manston Ramsgate
 Kent CT 12 5BF United Kingdom
 Phone 44 1843 255000
 Fax 44 1843 255902

Asia Pacific
 10 Toh Guan Road #07-01
 TT International Tradepark
 Singapore 608838
 Phone 65 6417 2388
 Fax 65 6417 2399

Warning: Back feed to a utility system can cause electrocution and/or property damage. Do not connect to any building's electrical system except through an approved device or after building main switch is open.

Our energy working for you.™

www.cumminspower.com

The HMI is designed for proper operation in ambient temperatures from -20 °C (-4 °F) to +70 °C (158 °F), and for storage from -30 °C (-22 °F) to +80 °C (176 °F).

The control board is fully encapsulated to provide superior resistance to dust and moisture. Display panel has a single membrane surface, which is impervious to effects of dust, moisture, oil and exhaust fumes. This panel uses a sealed membrane to provide long reliable service life in harsh environments.

The control system is specifically designed and tested for resistance to RFI/EMI and to resist effects of vibration to provide a long reliable life when mounted on a generator set. The control includes transient voltage surge suppression to provide compliance to referenced standards.

Certifications

PowerCommand meets or exceeds the requirements of the following codes and standards:

- NFPA 110 for level 1 and 2 systems.
- ISO 8528-4: 1993 compliance, controls and switchgear.
- CE marking: The control system is suitable for use on generator sets to be CE-marked.
- EN 50081-1,2 residential/light industrial emissions or industrial emissions.
- EN 50082-1,2 residential/light industrial or industrial susceptibility.
- ISO 7637-2, level 2; DC supply surge voltage test.
- Mil Std 202C, Method 101 and ASTM B117: Salt fog test.
- PowerCommand control systems and generator sets are designed and manufactured in ISO 9001 certified facilities.
- UL 508 recognized or Listed and suitable for use on UL 2200 Listed generator sets.
- CSA C282-M1999 compliance.
- CSA 22.2 No. 14 M91 industrial controls.

Warranty

All components and subsystems are covered by an express limited one year warranty. Other optional and extended factory warranties and local distributor maintenance agreements are available.

